

AMFLO® SONIC UFA-113 Ultrasonic flow sensor

Applications

- Ultrasonic flow sensor for use with energy calculators for heating and air conditioning applications in buildings and district heating
- Operates with water from 20 °C to 90 °C
- Threaded versions from DN 15 qp 0.6 m³/h to DN 40 qp 10 m³/h
- Flanged versions from DN 25 qp 3.5 m³/h to DN 65 qp 25 m³/h



Features

- Static sensor based on the ultrasonic transit time principle
- Tough stainless steel reflectors
- Measuring tube is easy to maintain
- Low start-up value and high measurement dynamics
- Flow-optimised design
- Dynamic range 1:250 in class 2 for qp 1.5 to 25 m³/h

Benefits

- Unaffected by particles, chemical substances or magnetite
- Wear-free as no moving parts
- Resistant to deposits
- High measuring accuracy
- No dirt filter required
- Low pressure loss and any chosen mounting position

Function

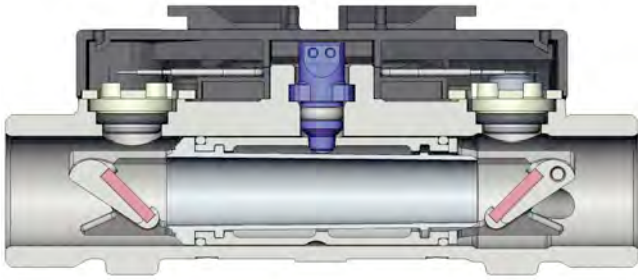

With the ultrasonic transit time measuring technique, ultrasonic signals are sent back and forth in the measuring tube between two ultrasonic transducers. One of the signals is sent in the direction of flow (downstream) while the other is sent against it (upstream). The difference in the upstream and downstream transit times is a measure of the flow rate in the measuring tube. The equation below describes the connection between transit times and flow speed:

$$v = K \times \frac{t_{\text{up}} - t_{\text{down}}}{t_{\text{up}} \times t_{\text{down}}} = K \times \frac{\Delta t}{t^2}$$

t_{down}	=	downstream transit time
t_{up}	=	upstream transit time
v	=	average flow speed
t	=	mean transit time
K	=	proportional factor

Mounting

When planning the installation, the following points should be taken into consideration:

The AMFLO® SONIC UFA-113 may only be used for water with temperatures between 20 and 90 °C. It can be mounted either on the warm side or the cold side of the pipe-work. The installation side must be recorded in the totaliser. The mounting direction is marked with an arrow on the device housing.

To reduce thermal load, the flow sensor should be mounted on the side of the pipe-work where the temperature is closest to ambient temperature. For the same reason the electronic unit should be mounted sideways.

The flow sensor is to be mounted in a protected, preferably dry location, without direct exposure to heat and sun. Make sure the sensor is installed sufficiently far away from possible sources of strong electromagnetic interference.

It is recommended that stop valves are fitted before and after the flow sensor to simplify dismantling. The flow sensor should be installed in a convenient position for service and operating personnel.

Seals on the flow sensor must not be damaged or removed! Their removal invalidates the warranty and calibration of the sensor.

Please consult the mounting and operating instructions for further information.

Inlet/Outlet

Recommendation for greater precision:

Inlet pipe length $\geq 5 \times \text{DN}$

Outlet pipe length $\geq 2 \times \text{DN}$

Insulation

Thermal insulation must only be fitted around the measuring tube. The electronic unit must not be insulated since it could overheat and become damaged.

Fluid and ambient temperature

The flow sensor type AMFLO® SONIC UFA-113 is not appropriate for operation in a water-condensing environment (cooling applications). In the case of $T_{\text{water}} < T_{\text{ambient}}$ or danger of condensation (cooling / air conditioning), the sealed version of the flow sensor AMFLO® SONIC UFA-114 must be used, with the pulse converter mounted away from the pipe-work.

The maximum permitted ambient temperature in all mounting positions is 55 °C.

Supply voltage

A 3.0 VDC lithium battery is fitted in the flow sensor, with a lifetime up to 12 years (depending on the configuration). The flow sensor may optionally be powered from an external supply e.g. from a calculator. It is not possible to replace the battery.

The battery's lifetime depends greatly on the output frequency. The output frequency at a nominal flow rate can be calculated as follows:

$$f \text{ [Hz]} = \frac{\text{Nominal flow rate, } q_p \text{ [m}^3\text{/h]}}{\text{Pulse value [l/Pulse]}} \times \frac{1000 \text{ l}}{1 \text{ m}^3} \times \frac{1 \text{ h}}{3600 \text{ s}} = \frac{\text{Nominal flow rate [m}^3\text{/h]}}{\text{Pulse value [l/Pulse]}} \times \frac{1}{3.6}$$

fmax [Hz]	Battery lifetime	Battery type
≤ 1	typically 12 years	3.0 VDC (Standard)
≤ 3	typically 10 years	3.0 VDC (Standard)
≤ 6	typically 7 years	3.0 VDC (Standard)

If a high pulse frequency is required, an external power supply should be used.

Technical features of external supply:

Power supply 3.0...5.5 VDC

Power consumption <130 mAh per year

Pulse current <10 mA

Pulse output module

The sensor has two pulse outputs:

- Pulse output for the connection to the pulse input of a heat meter (e.g. CALEC® MB, CALEC® light, CALEC® ST or AMTRON® X 50).
- High-resolution pulse output for temporally limited operation. This output also serves as parameter interface.

The pulse width can be adjusted between 1 ... 250 ms, with the pulse width being shorter than the pulse pause. The maximum output frequency with battery operation is 20 Hz.

The connecting cable has the following assignment:

Colour	Battery powered	External supply
white	+ volume pulse	+ volume pulse
yellow	Test pulse / communication	Test pulse / communication
blue	GND	GND
brown	not used	+ voltage supply

The flow sensor has a standard 4-pole pulse cable, 2.5 m in length. A 10 m long cable can be ordered as an option.

The connecting cable of the pulse module is connected to the terminals 10 (+) and 11 (-) of the heat calculator. This terminal designation corresponds to EN 1434.

Technical specifications

Hydraulic and mechanical specifications

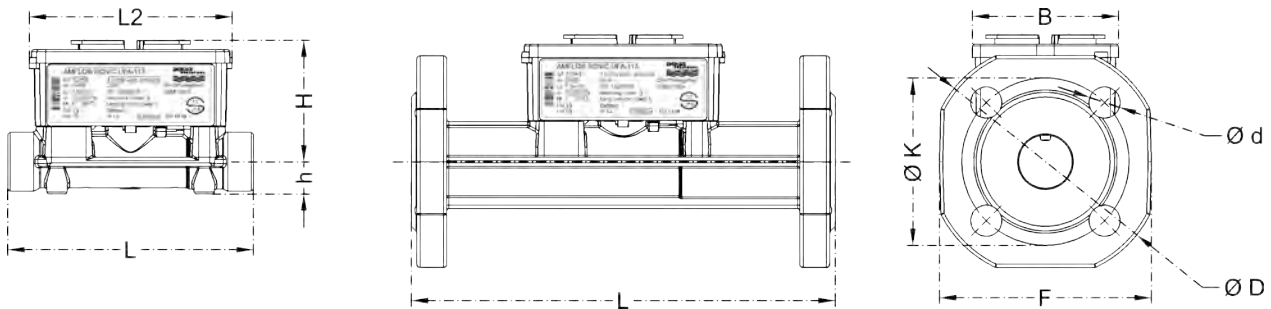

Dimensions of electronics module

$L2 \times B = 90 \times 65.5 \text{ mm}$

Nominal flow rate [m ³ /h]	qp = 0.6				qp = 1.0 / 1.5				qp = 2.5				qp = 3.5				qp = 6												
	15	20	20	20	15	20	20	20	16 (25)	16 (25)	16 (25)	16 (25)	20	20	20	20	25	25	25	25	25	25	25	25	25	25	25	25	
Nominal diameter DN	[mm]	15	20	20	20	15	20	20	20	16 (25)	16 (25)	16 (25)	16 (25)	20	20	20	20	25	25	25	25	25	25	25	25	25	25	25	25
Max. operating pressure PN	[bar]	16 (25)	16 (25)	16 (25)	25	16 (25)	16 (25)	16 (25)	25	16 (25)	16 (25)	16 (25)	25	25	25	25	25	25	25	25	25	25	25	25	25	25	25	25	25
Connection thread	[Zoll]	G ³ /4B	G1B	G1B	--	G ³ /4B	G1B	G1B	G1B	G1B	G1B	G1B	G1B	G1 ¹ /4B	G1 ¹ /4B	G1 ¹ /4B	G1 ¹ /4B	G1 ¹ /4B	G1 ¹ /4B	G1 ¹ /4B	G1 ¹ /4B	G1 ¹ /4B	G1 ¹ /4B	G1 ¹ /4B	G1 ¹ /4B	G1 ¹ /4B	G1 ¹ /4B	G1 ¹ /4B	G1 ¹ /4B
Flange	[mm]	--	--	FL20	--	FL20	--	--	FL20	--	--	FL20	--	--	FL20	--	FL20	--	FL25	FL32	FL32	--	FL25	FL32	FL32	--	FL25	FL32	FL32
Max. flow rate qs. (cut off)	[m ³ /h]	1.2	1.2	1.2	1.2	2/3	2/3	2/3	2/3	2/3	2/3	2/3	2/3	5	5	5	5	7	7	7	7	7	7	7	7	7	7	7	7
Min. flow rate qi	[l/h]	6	6	6	6	10/6	10/6	10/6	10/6	10/6	10/6	10/6	10/6	10	10	10	10	35	35	35	35	35	35	35	35	35	35	35	35
Threshold flow rate	[l/h]	1	1	1	1	2.5	2.5	2.5	2.5	2.5	2.5	2.5	2.5	4	4	4	4	12	12	12	12	12	12	12	12	12	12	12	12
Head loss Δp at qp	[mbar]	85	85	85	85	36/75	36/75	36/75	36/75	36/75	36/75	36/75	36/75	100	100	100	100	44	44	44	44	44	44	44	44	128	128	128	128
Kvs value	[m ³ /h]	2.06	2.06	2.06	2.06	5.27/1	5.27/1	5.27/1	5.27/1	5.27/1	5.27/1	5.27/1	5.27/1	7.91	7.91	7.91	7.91	16.7	16.7	16.7	16.7	16.7	16.7	16.7	16.7	16.7	16.7	16.7	16.7
Length L	[mm]	110	130	190	190	110	130	190	190	130	190	190	190	130	190	190	190	260	260	260	260	260	260	260	260	260	260	260	260
Height H	[mm]	78	80	80	80	78	80	80	80	80	80	80	80	80	80	80	80	84.5	84.5	84.5	84.5	84.5	84.5	84.5	84.5	84.5	84.5	84.5	84.5
Height h	[mm]	14.5	18	18	18	47.5	18	18	47.5	18	18	47.5	18	18	18	47.5	18	23	50	62.5	23	50	62.5	23	50	62.5	23	50	62.5
Diameter D	[mm]	--	--	105	105	--	--	--	105	--	--	--	105	--	--	--	105	--	114	139	--	114	139	--	114	139	--	114	139
Diameter d	[mm]	--	--	14	14	--	--	--	14	--	--	--	14	--	--	--	14	--	14	18	--	14	18	--	14	18	--	14	18
Width of the flange F	[mm]	--	--	95	95	--	--	--	95	--	--	--	95	--	--	--	95	--	100	125	--	100	125	--	100	125	--	100	125
Hole circle K	[mm]	--	--	75	75	--	--	--	75	--	--	--	75	--	--	--	75	--	85	100	--	85	100	--	85	100	--	85	100
Number of drillings		--	--	4	4	--	--	--	4	--	--	--	4	--	--	--	4	--	4	4	--	4	4	--	4	4	--	4	4
Weight	[kg]	0.76	0.85	0.96	2.75	0.76	0.85	0.96	2.75	0.76	0.85	0.96	2.75	0.85	0.96	2.75	0.85	1.5	3.5	4.8	1.5	3.5	4.8	1.5	3.5	4.8	1.5	3.5	4.8

Nominal flow rate [m ³ /h]	qp = 10				qp = 15				qp = 25								
	40	40	40	40	25	25	25	25	25	25	25	25	25	25	25	25	
Nominal diameter DN	[mm]	40	40	40	40	50	50	50	50	65	65	65	65	65	65	65	65
Max. operating pressure PN	[bar]	25	25	25	25	25	25	25	25	25	25	25	25	25	25	25	25
Connection thread	[Zoll]	G1 ¹ /2B	--	--	--	G1 ¹ /2B	--	--	--	--	--	--	--	--	--	--	--
Flange	[mm]	--	FL40	--	FL50	--	FL50	--	FL65	--	FL65	--	FL65	--	FL65	--	FL65
Max. flow rate qs. (cut off)	[m ³ /h]	20	20	20	20	30	30	30	30	50	50	50	50	50	50	50	50
Min. flow rate qi	[l/h]	40 ¹ /100	40 ¹ /100	40 ¹ /100	40 ¹ /100	60 ¹ /1150	60 ¹ /1150	60 ¹ /1150	60 ¹ /1150	250	250	250	250	250	250	250	250
Threshold flow rate	[l/h]	20	20	20	20	40	40	40	40	50	50	50	50	50	50	50	50
Head loss Δp at qp	[mbar]	95	95	95	95	80	80	80	80	75	75	75	75	75	75	75	75
Kvs value	[m ³ /h]	32.4	32.4	32.4	32.4	53.0	53.0	53.0	53.0	91.3	91.3	91.3	91.3	91.3	91.3	91.3	91.3
Length L	[mm]	300	300	300	300	270	270	270	270	300	300	300	300	300	300	300	300
Height H	[mm]	90	90	90	90	95	95	95	95	102.5	102.5	102.5	102.5	102.5	102.5	102.5	102.5
Height h	[mm]	33	69	69	69	73.5	73.5	73.5	73.5	85	85	85	85	85	85	85	85
Diameter D	[mm]	--	148	148	148	163	163	163	163	184	184	184	184	184	184	184	184
Diameter d	[mm]	--	18	18	18	18	18	18	18	18	18	18	18	18	18	18	18
Width of the flange F	[mm]	--	138	138	138	147	147	147	147	170	170	170	170	170	170	170	170
Hole circle K	[mm]	--	110	110	110	125	125	125	125	145	145	145	145	145	145	145	145
Number of drillings		--	4	4	4	4	4	4	4	8	8	8	8	8	8	8	8
Weight	[kg]	3	6.8	6.8	6.8	7.6	7.6	7.6	7.6	9.6	9.6	9.6	9.6	9.6	9.6	9.6	9.6

¹⁾ Only when installed horizontally

General data

Ambient temperature	5 °C ... 55 °C
Ambient humidity	<93 % r. h. (EN 1434), not appropriate for operation in a water-condensing environment
Type of protection	IP 54
Type of sensor	Static flow sensor according to EN 1434
Environment category	EN 1434 C
Water temperature	20 °C ... max. 90 °C with battery 20 °C ... max. 130 °C with external supply
Operating pressure	max. 16 bar for threaded version (25 bar on request) max. 25 bar for flanged version
Mounting position	horizontal / vertical, (does not affect accuracy)
Inlet, outlet pipe length	Recommendation: 5 x DN / 2 x DN
Measuring accuracy	better than EN1434-1 class 2 and 3

Pressure loss

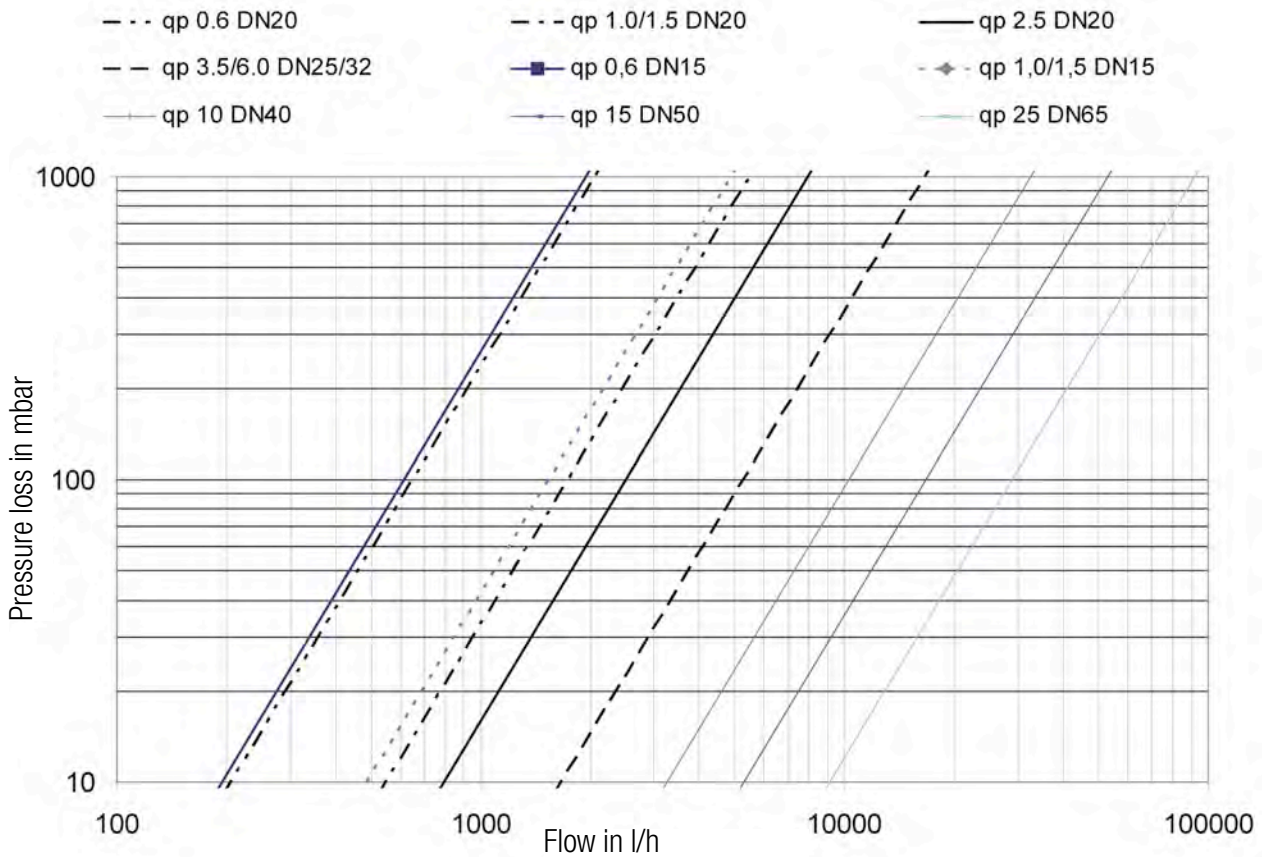

Measurement uncertainty

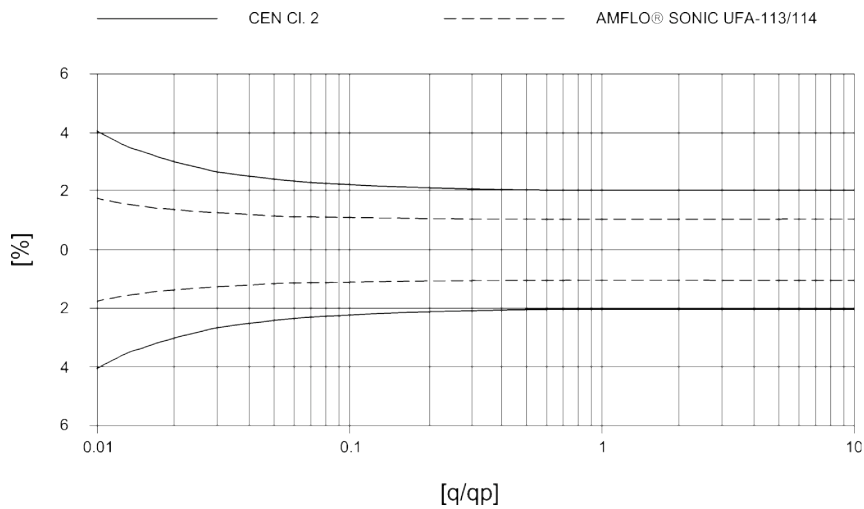

Electrical specifications

Battery powered	External supply	
Volume pulse output	not galvanically isolated	not galvanically isolated
Voltage supply	3.0 VDC lithium battery	3.0 - 5.5 VDC external
Output circuit	open collector	open collector
Contact loading	$U_{ce} \leq 30$ VDC $U_{ce} \leq 0.5$ VDC at $I_c \leq 20$ mA	$U_{ce} \leq 30$ VDC $U_{ce} \leq 0.5$ VDC at $I_c \leq 20$ mA
Output frequency	≤ 20 Hz	≤ 150 Hz
Pulse rating normal pulse	1 ml ... 5000 l, qp dependant	1 ml ... 5000 l, qp dependant
Pulse length normal pulse	1... 250 ms ± 10 %, length \leq pause	1... 250 ms ± 10 %, length \leq pause
Cable length	standard 2.5 m (optional 10 m)	standard 2.5 m (optional 10 m)

Order details

The table shows the standard programme. Further information on request.

Connection thread

Nominal flow rate	qp, [m³/h]	1.5	2.5	2.5	3.5	6	10
Nominal diameter DN	DN	15	20	20	25	25	40
Max. operating pressure PN	[bar]	16	16	16	16	16	25
Connection thread		G ³ / ₄ B	G1B	G1B	G1 ¹ / ₄ B	G1 ¹ / ₄ B	G1 ¹ / ₂ B
Length	[mm]	110	130	190	260	260	300
Max. temperature of heat carrier	[° C]	130	130	130	150	150	150
Pulse value for mains version	[l/Impuls]	1	1	1	1	1	1
Pulse duration	[ms]	100	100	100	100	100	100

Version	Art. No.						
Lithium battery 3.0 VDC (life span typ. 12 years)	93963	93964	93965	93966	93967	94481	
Metrological CE declaration (order separately)	96158	96158	96158	96158	96158	96159	

Spécial versions: Art. No. 180441

Flanges

Nominal flow rate	qp, [m³/h]	3.5	6	6	10	15	25
Nominal diameter DN	DN	25	25	32	40	50	65
Max. operating pressure PN	[bar]	25	25	25	25	25	25
Connection thread		FL25	FL25	FL32	FL40	FL50	FL65
Length	[mm]	260	260	260	300	270	300
Max. temperature of heat carrier	[° C]	150	150	150	150	150	150
Pulse value for mains version	[l/Impuls]	1	1	1	1	10	10
Pulse duration	[ms]	100	100	100	100	100	100

Version	Art. No.						
Lithium battery 3.0 VDC (life span typ. 12 years)	93968	93969	93970	94482	94483	94484	
Metrological CE declaration (order separately)	96158	96158	96158	96159	96159	96159	

Spécial versions: Art. No. 180441

CE conformity and approval

The instruments are approved according to the MID directive 2004/22/CE (No. DE 06-MI004-PTB017). The meters can be delivered with a conformity declaration, if specified when ordering. Instruments for commercial heat measurement are subject to commercial verification in most countries. Equipment subject to this obligation must be recalibrated after expiry of the calibration period. The operator is responsible for compliance with the regulations.

DISTRIBUTOR:

Contact, Address and Stamp

HEAD OFFICE:

AQUAMETRO AG
Ringstrasse 75
CH-4106 Therwil
Phone +41 61 725 11 22
Fax +41 61 725 15 95
info@aquametro.com



www.aquametro.com