

# Industrial Fuel Polishing System 80 GPH

The Fuel Polishing System removes water, bacterial growth, and other particulate from diesel that are detrimental to fuel systems and thereby resolving many issues related to degraded fuel.

## Basic Features

- Primary filtration - Separ Filter with vacuum gauge
- Secondary filtration - 2 micron
- Available in 12V and 24V
- Aluminum cover and base with spill containment
- Mountable base
- Water level alarm and shutoff
- Vacuum alarm and shutoff
- Spill alarm and shutoff

## Optional Features

- Enclosure
- Enclosure with stand

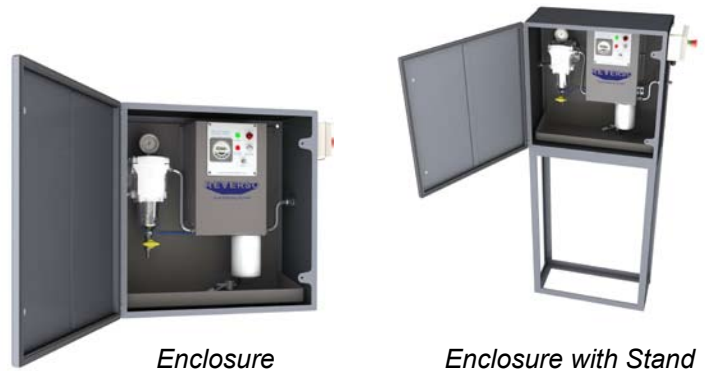

## Technical Specifications

<b>Flow Rate</b>	80 GPH / 303 LPH	
<b>Inlet / Outlet</b>	1/2" Male JIC	
<b>Voltage</b>	12V or 24V	
<b>Amp. Draw</b>	2.7A, 12V 1.4A, 24V	
<b>Circuit Breaker</b>	10A, 12V 5A, 24V	
<b>Lift</b>	4 ft / 1.2 m	
<b>Pump Type</b>	Gear Pump	
<b>Primary Filtration</b>	Standard 30 micron	
<b>Secondary Filtration</b>	2 micron	
<b>Wall Mount Dimensions</b>	A	22.2" / 564 mm
	B	22.2" / 564 mm
	C	7.9" / 200 mm
<b>Enclosure Dimensions</b>	A	28.5" / 724 mm
	B	24" / 610 mm
	C	10" / 254 mm
<b>Enclosure with Stand Dimensions</b>	A	28.5" / 724 mm
	B	59.75" / 1518 mm
	C	10" / 254 mm

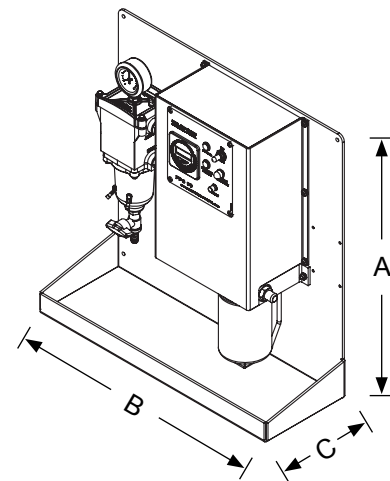

## Replacement Elements

<b>00510/50</b>	10 micron
<b>00530/50</b>	30 micron
<b>00560/50S</b>	60 micron, stainless steel