

Industrial Fuel Polishing System 600 GPH

The Fuel Polishing System removes water, bacterial growth, and other particulate from diesel that are detrimental to fuel systems and thereby resolving many issues related to degraded fuel.

Basic Features

- Primary filtration - Separ Filter with vacuum gauge
- Secondary filtration - 2 micron
- Available in 110V
- Aluminum cover and base with spill containment
- Mountable base
- Water level alarm and shutoff
- Vacuum alarm and shutoff
- Spill alarm and shutoff
- Fuel conditioner

Optional Features

- Enclosure
- Enclosure with stand



Enclosure



Enclosure with Stand

Technical Specifications

Flow Rate	600 GPH / 2271 LPH	
Inlet / Outlet	1" Male JIC	
Voltage	110V	
Amp. Draw	3.4A, 110V	
Circuit Breaker	10A, 110V	
Lift	11.5 ft / 3.5 m with foot valve above liquid level	
Pump Type	Vane Pump	
Primary Filtration	Standard 30 micron	
Secondary Filtration	2 micron	
Wall Mount Dimensions	A	28.4" / 721 mm
	B	28.2" / 716 mm
	C	10.9" / 276 mm
Enclosure Dimensions	A	34.5" / 876 mm
	B	30" / 762 mm
	C	12" / 305 mm
Enclosure with Stand Dimensions	A	34.5" / 876 mm
	B	59.75" / 1518 mm
	C	12" / 305 mm

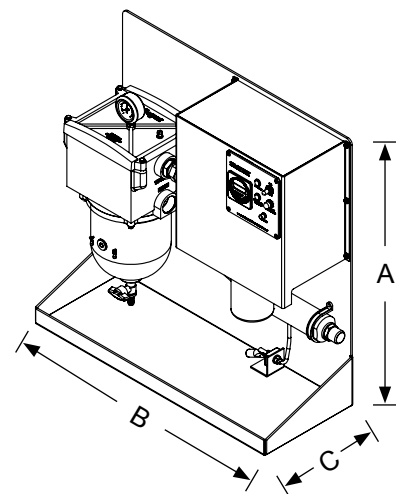

Replacement Elements

04010	10 micron
04030	30 micron
04060S	60 micron, stainless steel