

**Carter® Ground Fueling**  
Hydrant Coupler - API Style

Model 64810



*Powering Business Worldwide*

# Design Concepts

Eaton's Carter brand Model 64810 is the latest coupler design and it supersedes Models 64800 and 60700-1. It is used for air reference pressure control systems.

The lower half of Model 64810 has been completely redesigned. This new lower half incorporates three (3) detent pins, an internal collar locking device and collar lifting handles [both "short" (standard) or "tall" (option "T")], providing improved ergonomics and operational handling during disconnect.

Earlier coupler Models 64800 and 60700-1 can be retrofitted to gain these new features by changing only the lower half.

## Features

- Mates all standard hydrant valves in accordance with API 1584
- Air/fuel sense ports parallel to outlet
- All ports with straight O-ring sealed threads
- 2-½, 3 & 4 inch NPT or BSPP outlet threads available

- Air bleed under sealed screw
- Closing time adjustment accessible without removal of air port fitting
- External collar locking device eliminated
- Studs used for connecting lower half, reducing chance of over-tightening connecting fasteners
- Outlet of elbow flanged to accept various outlet male adapter fittings. Options to mate to older quick disconnects (QD) available, reducing maintenance costs if the male fitting is damaged.
- Outlet QD has thumb latches for easy disconnecting without use of any tools
- Optional carrying handles available. Transverse mounting standard, parallel optional. A second QD mounted handle is also available.
- Carriage affixed by studs. No special length bolts required,

- reducing chance of error when carriage is added in the field.
- Port to connect to hydrant provided on coupler — no special hose assembly required
- Changes have been made without an increase in weight

## Operation Information

Model 64810 coupler is a direct spring loaded pressure control unit that is controlled by the air reference pressure provided from the vehicle system. Operation of Model 64810 is nearly identical to earlier models 64800 and 60700-1, but the redesigned lower half provides improved operational handling.

## Technical Data

- Weight — (basic coupler) 27 lbs (12.247 kg)
- Operated by vehicle air reference pressure
- Working pressure — 200 psi (13.793 bar)

- Proof pressure — 450 psi (31.034 bar)
- Closing time — 2-5 seconds (adjustable)
- Opening time — 5-10 seconds (no adjustment)
- Overshoot — 40 US gal. maximum at 800 USgpm
- Air pressure operated — nominal bias (air pressure required above control pressure) — 25 psi (1.724 bar). Bias increases to approximately 33 psi (2.276 bar) at flow rates up to 1,200 USgpm
- Fully open pressure drop — 24 psi (1.655 bar) at 1,100 USgpm when mated to Model 60554 hydrant valve

## Envelope Dimensions

Dimensions shown in inches (millimeters)

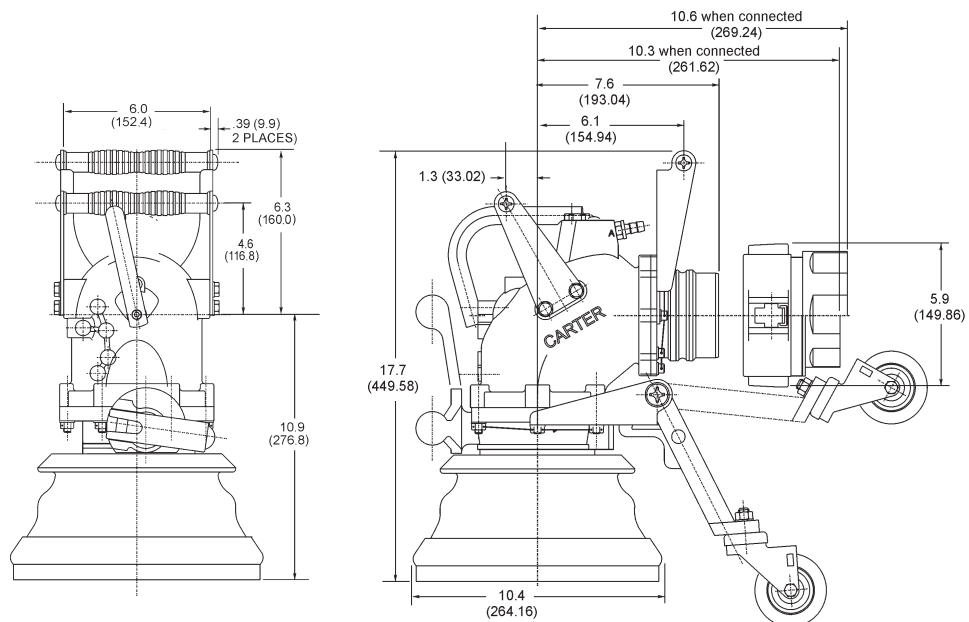

Various options are available on the Model 64810 coupler. The part number system is described to the right. The complete part number is comprised of four parts, as explained in the tables below.

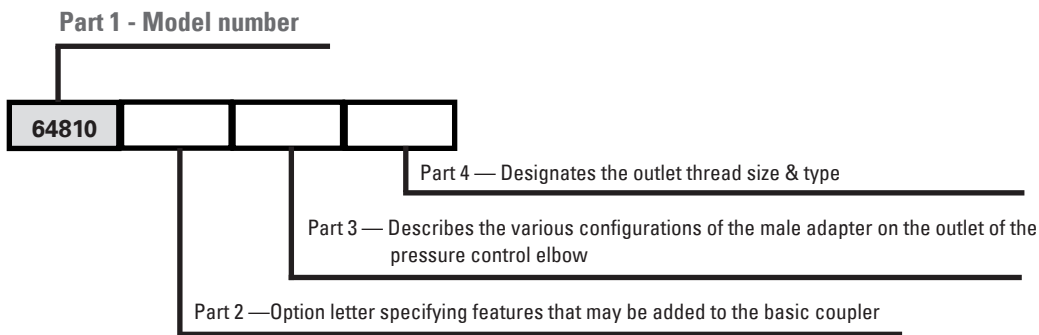

**Part 2**

One or more of the options described at right may be added to the basic model number 64810 to obtain desired features.

Option Letter	Description	Option Letter	Description
B	Adds folding handle	R	Adds 90° elbow ¼ inch FNPT for air operated hydrant valve actuation
C	Adds product selection	T	Adds “tall” lower collar lifting handle
D	Adds lockwire to flange joint fasteners	W	Adds carriage assembly
E	Adds API style air/fuel QD	X	Adds safety clip to outlet disconnect (option 2 only)
F	Adds hose barb fittings to air and fuel ports	Y	Adds handle assembly at outlet
H	Adds 3/8 inch FNPT fitting to both air and fuel sense ports	Z	Replaces standard transverse carrying handle at centerline of coupler with handle parallel to outlet (47214)
J	Adds 3/8 inch hose barb fittings to both air and fuel sense ports		

**Part 3**

One of the options described at right must be added to determine the outlet male adapter configuration.

Option	Description	Option	Description
2	Adds 3 inch male adapter to mate standard thumb latched female QD.	4	Adds adapter to mate customer furnished Model 60600 (except option K) type QD
3	Adds 4 inch male adapter to mate 60700-1 style female QD		

**Part 4**

One of the options described at right must be added to specify the outlet thread size and type.

Option Letter	Description	Option Letter	Description
H	Adds 2-½ inch NPT thread female QD. Can be used only with option 2 from part 3.	N	Adds 4 inch BSPP thread female QD
K	Adds 2-½ inch BSPP thread female QD. Can be used only with option 2 from part 3.	P	Adds 4 inch NPT thread female QD
L	Adds 3 inch NPT thread female QD	Q	Adds 2 inch NPT thread female QD. Can be used only with option 2 from part 3.
M	Adds 3 inch BSPP thread female QD	R	Adds 4 inch -8 NPSC thread female QD. Can be used only with option 3 from part 3.
		S	Adds 2 inch BSPP thread female QD. Can be used only with option 2 from part 3.

**Note:** If part four is left blank, no female QD will be shipped. This is a proper designation when it is desired to use a Model 64810 to replace a Model 60700-1, 60600 or 60600-1 coupler. In this case, part three must correctly designate the proper male adapter fitting.

**Examples:**

- 64810BFX2H Coupler with folding handle, hose barbs in all air/fuel ports, safety ring on QD, standard thumb latch QD with 2-½ inch NPT threads
- 64810CT3 Coupler with male adapter fitting to mate to 60700-1 (no female QD provided) and “tall” lower collar lifting handles

**Eaton**  
**Aerospace Group**  
**Conveyance Systems Division**  
**9650 Jeronimo Road**  
**Irvine, California 92618**  
**Phone: (949) 452 9500**  
**Fax: (949) 452 9992**

Eaton  
Aerospace Group  
Conveyance Systems Division  
90 Clary Connector  
Eastanollee, Georgia 30538  
Phone: (706) 779 3351  
Fax: (706) 779 2638

Eaton  
Aerospace Group  
Conveyance Systems Division  
300 South East Avenue  
Jackson, Michigan 49203-1972  
Phone: (517) 787 8121  
Fax: (517) 787 5758

Eaton  
Aerospace Group  
Conveyance Systems Division  
11642 Old Baltimore Pike  
Beltsville, Maryland 20705  
Phone: (301) 937 4010  
Fax: (301) 937 0134

Eaton  
Aerospace Group  
Conveyance Systems Division  
15 Pioneer Ave.  
Warwick, Rhode Island 02888  
Phone: (401) 781 4700  
Fax: (401) 785 4614

Eaton S. A.  
Aerospace Group  
Conveyance Systems Division  
2 Rue Lavoisier BP 54 78310  
Coignieres, France  
Phone: (33) 130 69 30 00  
Fax: (33) 130 69 30 56

Eaton Limited  
Aerospace Group  
Conveyance Systems Division  
Broad Ground Road  
Lakeside, Redditch  
Worcestershire  
B98 8YS  
United Kingdom  
Phone: (44) 1527 517555  
Fax: (44) 1527 517556

Eaton S.A  
Aerospace Group  
Conveyance Systems Division  
62 Chemin De Pau  
64121 Serres-Castet  
France  
Phone: (33) 559 333 864  
Fax: (33) 559 333 865

Eaton Fluid Power GmbH  
Rudolf-Diesel-Str. 8  
82205 Gilching  
Germany  
Phone: +49 8105 75 0  
Fax: +49 8105 7555

Vickers Systems Pte Ltd  
Aerospace Group  
Conveyance Systems Division  
Lot 512, Jalan Delima,  
Batamindo Industrial Park  
Batam 294533, Indonesia  
Phone: (62) 770 611823  
Fax: (62) 770 611821

Eaton  
Aerospace Group  
9650 Jeronimo Road  
Irvine, California 92618  
Phone: (949) 452 9500  
Fax: (949) 452 9555  
[www.eaton.com/aerospace](http://www.eaton.com/aerospace)

©2011 Eaton  
All Rights Reserved  
Printed In USA  
Form No. TF100-129  
February 2011